

Reel Direction

A publication of the Tuboscope Coiled Tubing/Pressure Control Group.

Spring 1998

Tulsa Equipment Manufacturing Joins Tuboscope



In December '97, Tulsa Equipment Manufacturing (TEM) was purchased by Tuboscope. TEM becomes the sixth company to join Tuboscope's Coiled Tubing/Pressure Control Group.

Located in Tulsa, Oklahoma, TEM is a designer and manufacturer of High Pressure Pumping Equipment and Cement Pumping Equipment for the oilfield servicing industry. John Power has been appointed General Manager of TEM. John has spent the last 15 years involved in the operation and manufacture of Oilfield Service Pumping Equipment, most of this time with Schlumberger Dowell. Joining John as TEM management staff are current TEM personnel Tom Allen – Engineering Manager, Rick Coody – Sales Manager, Randy Burchette – Manufacturing Manager, and Linda Laird – Production Control Manager.

TEM is also one of the few companies capable of manufacturing a dependable state of the art "Automatic Density Control System". This patented system has moved TEM into a world leadership position as a Cement Pumping Equipment supplier. TEM's products include:

- High Pressure Fluid Pumping Units
- Frac Blending Units
- Cement Pumping Systems
- Acid Pumping Units
- Combination Cementer/Acidizer
- Cement Batch Mixer
- Automatic Density Control System ♦



Hydra Rig HR-480 injector being tested to vary dynamic loading capability.

Update – Hydra Rig Coiled Tubing Test Well Facility

In the last issue of "Reel Direction" Hydra Rig advised plans for an on-site Coiled Tubing Dynamic Test facility.

The facility was completed in January of this year. Hussein Barzin, Hydra Rig Manager of Quality, says the new test facility is being utilized for both customer requested dynamic and new product/R&D "testing". ♦

In This Issue

PCE's New CT Tool Direction
Page 2

TOT's New Cutter
Page 3

TEM's Double Pump Cementer
Page 4

SSR's New Venture
Page 5

Hydra Rig's 25th Anniversary
Page 6

Hydra Rig Production Record
Page 6

CTES's New Measuring Device
Page 7

Reel People and Places
Back Page

PCE Charts New Direction For Coiled Tubing Tools Sales In Response To Market Research



Pressure Control Engineering is launching a new standardized range of Coil Tubing Tools and associated products to offer the market greater ease of access to the latest advances in Coiled Tubing Tool's technology.

The move is in direct response to research PCE carried out with a number of key customers.

The following highlights the primary points obtained from this research:

- The customers wanted PCE's unique problem solving technology made readily available and accessible as a standard product range.
- The customer's prime consideration was having easy access to comprehensive information about Coiled Tubing Tools to make selections for appropriate applications fast and straightforward.
- Better access to information regarding the features and benefits of each tool. This was seen as particularly beneficial to help increase the working knowledge of the product range.
- More detailed information on spare parts.

In addition to this research PCE has also recently completed a review on cost and pricing. PCE's Bob Norris comments: "By increasing production of our main product and spares, we have not only increased stock levels and improved delivery times but we have made substantial unit cost savings which are being passed directly on to the customer. PCE can now compete very aggressively on price."

The "New Direction" is being supported by a brand new 152 page CD ROM catalogue which provides detailed graphic, technical, operational and spare part information on over 60 main products in a number of core sizes. The CD ROM, which was developed in-house by Trevor Alner and Warren Ackroyd, is available in addition to PCE's standard catalogue and has been designed with ease of use in mind.

As Trevor confirms, "We were very aware that the information needs to be quickly accessible to a wide range of personnel, some of whom may not be as computer literate as others. The information is presented in any easy to use manner, with straightforward point and click direction to navigate through 152 pages of information."

PCE sees the above as a natural progression of its specialist tool design service through which it will continue to engineer solutions and solve specific problems in its capacity as a major contributor in the coiled tubing tools industry. ♦

Copies of the CD ROM catalogue are available by contacting Bob Norris at PCE:
TEL: +44 1202 631817
FAX: +44 1202 631708
E-MAIL: sales@pce.co.uk



PCE's new catalog is available on a CD ROM, which makes it easy for you to find all the graphical, technical, operational and spare part information on over 60 of our main products.



TOT Introduces New Coiled Tubing Cutter



In response to the needs of the Coiled Tubing industry Texas Oil Tools has developed a line of Tubing Cutters for use in a variety of applications. Two models are currently available for shearing up to 2-7/8" OD tubing. The hydraulically operated cutter comes in a configuration as light as 42 lbs for easy handling.

The cutter generates over 60,000 lbs of force and requires only one hydraulic hose connection. An air spring returns the blades to the full open position when hydraulic pressure is vented.

Emergency Rig Disconnect

Cutting the coiled tubing string between the reel and injector can be done remotely without exposing personnel to the dangers of manually cutting the string. The hinged cutting head allows the cutter to be easily positioned in the middle of long tubing strings for such emergency shearing operations.

Removing Production Tubing From Abandoned Wells

By positioning the cutter above a well, tubing can be cut into manageable pieces as it is being pulled. Several hundred cuts can be made on heavy walled tubing on one set of cutter blades.

Scrapping Reels Of Tubing

Large reels of tubing can be quickly cut into manageable pieces for the scrap bin. The cutter works well with a hand pump and can be operated in remote locations where rig power is not accessible. ♦

TOT Begins Construction On A New Facility



Carl Adams, General Manager of Texas Oil Tools announced construction has begun on a new manufacturing facility for (TOT) in Conroe, Texas. The new building will be located adjacent to the existing facility, which has housed manufacturing for both TOT and Tuboscope's Brandt/EPI Division. This new facility will be dedicated 100% to TOT and will accommodate all of TOT's manufacturing needs. The building will have 37,500 sq. ft. consisting of 7,500 sq. ft. office space and 30,000 sq. ft. machine shop. The machine shop and service area will be climate controlled and have four 10 ton overhead cranes. Completion is scheduled for mid-July of this year. ♦

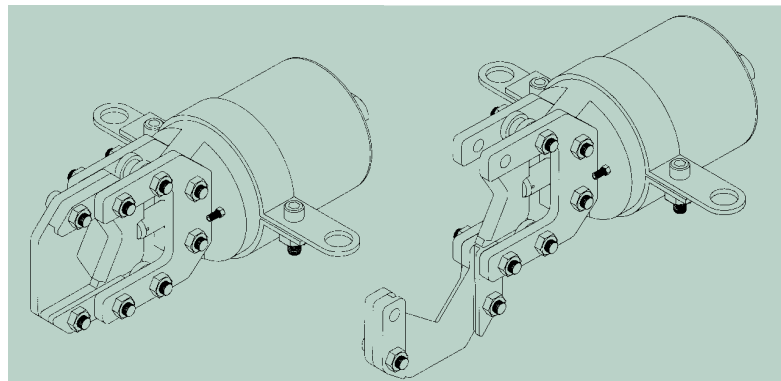

The cutter comes in two models. The light weight BC-4500 and the low pressure BC-2500.

Capabilities		
	BC-4500	BC-2500
Working Pressure	4500 PSI	2500 PSI
Weight	42 lbs.	83 lbs.
Pressure to Shear 80 ksi 2-7/8" OD x .204" wall tubing	3700 PSI	1600 PSI
Pressure to Shear 80 ksi 2-3/8" OD x .224" wall tubing	4200 PSI	2200 PSI

TEM's Double Pump Cementer With Continuous Automatic Mixing (CAM)



TEM'S CPT-800 is a truck mounted Double Pump Cementer (also available, skid or trailer mounted), capable of performing high pressure pumping services, with a total of 900 BHP available. It incorporates a high energy re-circulating mixing system that can control mixing density automatically.

The unit has a clean design, which takes into consideration ease of maintenance and operation with all systems controlled from the operators' console. It is capable of reliably performing the most demanding cementing jobs. Quality is evident in both the design and manufacturing. TEM has ISO 9001 certification of its engineering and manufacturing processes.

The Double Pump Cementer has two 500 HP triplex pumps driven by two 8V-92TA engines with Allison HT-750 DRD automatic transmissions. The 8V-2TA engines also provide power for the recirculation centrifugal, and the boost pump centrifugal. Auxiliary power is provided by the chassis engine to drive the mix water centrifugal pump and hydraulic agitator. At the heart of the TEM system are three component groups working interactively to produce the most consistent quality cement possible:

- The Cement Control Valve
- The High Energy Mixer
- Automatic Metering System

TEM's Double Pump Cementer offers many special features some of which are not available on competitors designs. Tom Allen, TEM's Engineering Manager says, "We did not have an existing design, this left us with a clean sheet of

paper to do it right. We had the opportunity to design the "best" cement system available today and we think we have done that." By "best" Tom (who has spent 20 years with a major service company in operation, design and R&D of cementing equipment) said, "We brought together the best aspects of – Operation – Maintenance – Service – Design and the latest "proven" new technology.

The following special features are available as standard on TEM's CPT-800 Double Pump Cementer. Many of these features are propriety to TEM and not available on competitors' designs.

Centrifugal Boost Pump for Triplex Pumps

- Smoother operation - eliminates potential triplex pump cavitation/ loss of prime
- More accurate flow control

Backup Recirculating & Boost Pumps

- If either the Recirculation Pump or the Boost Pump should fail, the other pump will act as a back up and pick up the function of the failed pump.

Continuous Automatic Mixing Density Control

- Automatically controls cement slurry density
- Stores three slurry designs
- Built-in pre-job system check
- Built-in manual simulator
- Key job parameters recording



Dust Eliminator

- Eliminates dust in tank
- Continuously separates bulk air from cement
- Minimizes slurry air entrapment

High Energy Mixing System

- Maximizes wetting of all cement and therefore produces more predictable slurry characteristics, resulting in more successful cementing jobs and better customer satisfaction.

System Simulator Program

- Provides function verification to test all systems
- Allows job simulation for training personnel

Acceptance of TEM's new Double Pump Cementer unit with patented High Energy Mixer has come much faster and stronger than expected. Rick Coody (TEM Sales Manager) stated, "In less than two years, TEM's Double Pump Cementer with patented Continuous Automated Mixing System (CAM) has been acknowledged as an industry leading design. Sales by the end of 1998 should reach 20± Double Pump Cementer units and an additional 30± CAM systems. The individual CAM systems have been purchased by a TEM competitor to install on their equipment and by a major cement service company for retrofit." Coody also said, "By the end of 1998, there will be TEM Cement Units operating in the Far East, South America, USA, Canada, and the Middle East." ♦

The CAM High-Energy Mixer and continuous recirculating system delivers a slurry of consistent quality and density through the job.

SSR (International) Ventures Into The Coiled Tubing Drilling Market.



With the current trend for Coiled Tubing Drilling operations becoming more popular, SSR has recently finished the first of a range of A60 DNV specification Coiled Tubing Drilling Control Cabins for a Major North Sea operator who is heavily involved in this market in both the British and Norwegian sectors of the North Sea.

The project serves to demonstrate and confirm the benefits available to the customer with two of the main companies within the group working together (Hydra Rig & SSR) to produce a product that meets with their specific requirements. It also endorses the strengths available within Tuboscope in this sector of the Oil Industry.

The rigorous standards of A60 specification provides an environment that has an overpressure system allowing the use of electrical equipment which is not intrinsically safe in a zone 2 area, and will provide a working area safe from fire up to 2800 Deg F for a one hour period. The DNV lifting specification this unit had to meet, is one of the most demanding found throughout the world.

The cabin was built by SSR in Aberdeen with assistance by Hydra Rig on the hydraulic systems required to match the customer needs on their current equipment specification. The end result is a cabin built by SSR to operate all the typical Hydra Rig and Texas Oil Tools coiled tubing equipment, Injectors, BOP's, stripper's etc., and also the additional controls associated with CT drilling, computers system & Fluid pumps controls from the safe environment of the A60 cabin.

The cabin has a few features that enhance the design, and add individually to the product, one being the special two plane front window, (adapted from a wireless design in use by SSR for over 5 years). This item is to give the operator the best possible viewing position to both the reel/drill floor area and the workspace in front of the cab improving safety and operator confidence in the system. The cabin also features a back up system for the computers and overpressure system, which in the event of losing power (by accident or in an emergency shut down situation) kicks in automatically and gives the Control Cabin the ability to operate independently for one hour allowing personnel the opportunity to bring the coil operation to a safe position before shutting down.

The second and third cabins are currently under construction and inquiries from other operators have highlighted the interests in the marketplace for this type of equipment, and a commitment by both the operators and oil companies to Coiled Tubing Drilling projects. ♦



This Coiled Tubing Drilling Control Cabin gives operators a safe environment from which to operate various coiled tubing equipment, injectors, BOP's and strippers.

SSR Selling China



SSR has recently produced a company first by gaining their initial sale in China, a substantial £750,000.00 order for 5 "Omega" type multi-function Wireline Units and Power Packs. The Omega is a well proven and accepted design with customers including Halliburton, Marathon and Camco amongst others. The new units are currently under production with delivery planned for summer. ♦

Hydra Rig Will Celebrate Its 25th Year Anniversary In 1998.

The Past

Founded in early 1973, Hydra Rig's first product line and namesake was the Hydraulic Workover Unit. Known in the industry as a "Snubbing Unit", these unique units allow the workover of an oil or gas well to be performed under pressure without the use of "kill" fluid in the well which could result in well damage.

In 1980 Hydra Rig added Coiled Tubing Units as a major product line, and in 1982, Nitrogen Equipment was added. Hydra Rig's reputation was quickly established as the leading manufacturer in these product lines.

Today

Hydra Rig has grown substantially over the past 25 years from the original staff of 5 to 200± employees today. Although the manufacturing facility has expanded substantially, the location is still at the original address is Ft. Worth, Texas.

Hydra Rig's strongest asset has been the strength and dedication of the people who work here. Joe McAnally, who has been with Hydra Rig 20 years, and President from 1990 to 1998 (before becoming Vice-President of Tuboscope Coiled Tubing/Pressure Control Group)

said, "It is the employee dedication that has taken Hydra Rig to the position of being the world leader in Snubbing, Coiled Tubing and Nitrogen Equipment." Hydra Rig has supplied more than 200 Snubbing units, 400 Coiled Tubing Units and 250 Nitrogen Units.

The Future

Hydra Rig has constantly "set the pace" in its industry.

Hydra Rig is moving forward with new designs in both conventional Coiled Tubing and Nitrogen Equipment and in Coiled Tubing Drilling Equipment. It is Hydra Rig's goal to maintain this position as industry leader into the next century.

We know that our success would not be possible without a strong and loyal customer base. We look forward to working with our customers as we continue to go forward. ♦

Hydra Rig Sets New Productions Record

Hydra Rig produced twelve major units for the month of February 1998. Dave Phillips, Hydra Rig Manufacturing Manager reports that these units included both Coiled Tubing Units and Nitrogen Pumping equipment. Several of these Coiled Tubing Units were destined for a major program in Mexico. All arrived on time to satisfy customer requirements. Hydra Rig employees celebrated this achievement with a customer sponsored barbecue. Phillips added that credit for production record was due to the hard work and dedication of the employees who "made it happen". ♦



Hydra Rig's first Coiled Tubing Unit (CT-1) in operation in 1980.

Hydra Rig Delivers First Nitrogen Equipment Into Russia

In March, Hydra Rig shipped three LN₂ systems to Russia. These units were destined for Tomseneft Oilfield. The units were truck mounted with maximum flow rate of 90,000 SCFH, a working pressure of 10,000 PSI and a 3,000 gallon LN₂ tank. The units were equipped with an enclosed operator cabin to allow operation in severe cold climate. Randy Graves, Hydra Rig's Vice President of Sales stated, "There is a definite need in the CIS for oilfield nitrogen equipment and Hydra Rig is committed to serving this need." ♦



New Measuring Device Lowers Risk of Costly Tubing Failures



Mechanical damage is one of the largest causes of coiled tubing failures.

Failures that are not only costly and time consuming for everyone but also potentially dangerous.



This Coiled Tubing Diameter Ovality Gauge is one of the state-of-the-art systems designed for the coiled tubing industry.

Detecting tubing imperfections such as necked or ballooned sections of mechanical damage before entering the well is key to preventing failures from with these types of problems.

CTDOG, short for Coiled Tubing Diameter and Ovality Gauge, the CTDOG was designed to alarm the operator of impending tubing problems by monitoring real-time diameter growth and ovality during coiled tubing operations. The CTDOG is the only commercially available real-time diameter and ovality-measuring device on the market today.

To compute ovality, the CTDOG measures six diameters at the same time on six axis across the coiled tubing. The minimum and maximum ovality diameter and the maximum ovality are transmitted each second to a data acquisition system for permanent recording. This data is compared to user defined limits. If a limit is extended, warning lights and a buzzer from display in the control cabin notify the operator of the problem.

Operations using the CTDOG have the advantage of taking remedial actions to correct problems before the pipe enters the well, thus reducing the number of tubing failures and improving the economics of coiled tubing operations.

CTDOG can be used as a stand-alone inspection device or it can be used with CTES' Cerberus™ CT modeling software and the Orion™ data acquisition system, to create a fully integrated, real-time coiled tubing monitoring system.

Cerberus™ includes models for fatigue, hydraulics, limits and forces and receives real-time job data such as depth, weight, pressures, and flow rates from the Orion™ and now diameter growth and ovality from the CTDOG.

The CTDOG can also be used in conjunction with Tuboscope's CT Scope, a device that measures wall thickness and finds cracks in coiled tubing. ♦

CTES, Growing By Leaps & Bounds



CTES recently added several engineers and software programmers to its team of coiled tubing specialists.

As one might guess, plans for a new office building are in the works. CTES forecasts the completion of the new building sometime during mid summer 1998. We will keep you advised of new facility status. ♦

Reel People And Places

Ian Sutherland has been named Sales Manager for SSR International Ltd. For the past three years Ian has been in charge of TOT sales for the North Sea.

F. A. Waters has joined Hydra Rig as General Manager. F. A. replaced Joe McAnally who is now Vice President in charge of Tuboscope's Coiled Tubing/Pressure Control Group, which Hydra Rig is a part of. F.A. has spent the past several years in the Halliburton/OTIS organization holding various management positions.

Elzie Lance announced his retirement from Hydra Rig. He has been with Hydra Rig for the past 23 years, with the last 10 years as Vice President of R&D. He will continue to work with Hydra Rig on a consulting basis. With retirement, Elzie will only be required to be at Hydra Rig "40" hours a week.

Claude Bryant recently joined CTES as Engineering Manager. Claude has a masters degree in Engineering and has spent the past 2 years with Schlumberger's Advanced Drilling Systems Group. ♦



Pressure Control Engineering
Holton Road
Holton Heath Trading Estate
Poole, Dorset, BH16 6LT. UK
Phone: (01202)631817
Fax: (01202)631708
E-mail: sales@pce.co.uk



SSR International
Wellheads Crescent
Dyce Industrial Park
Dyce, Aberdeen AB2 0GA. UK
Phone: (01224)725462
Fax: (01224)771606
E-mail: 101544.2731@compuserve.com



Coiled Tubing Engineering Services
P.O. Box 2178
Conroe, Texas 77305-2178 U.S.A.
Phone: (409)521-2200
Fax: (409)756-5175
<http://www.ctes.com>



Texas Oil Tools
P.O. Box 2327
Conroe, Texas 77305-2327 U.S.A.
Phone: (409)441-0006
Fax: (409)756-8102
E-mail: totsales@lcc.net



Tulsa Equipment Manufacturing
4045 N. Garnett
Tulsa, Oklahoma 74116 U.S.A.
Phone: (918)234-4466
Fax: (918)234-4471
E-mail: mhoyle@flash.net

Hydra Rig
6000 East Berry Street
Ft. Worth, Texas 76119 U.S.A.
Phone: (817)457-3825
Fax: (817)457-3897/5237
E-mail: hrisales@whytel.com

For more specific information, check off your topics of interest and fax this page to Mike Hoyle at 1-817-457-6461. Or call Mike directly at 1-817-457-3825.

- | | |
|--|---|
| <input type="checkbox"/> TEM Products | <input type="checkbox"/> TEM Double Pump Cementer |
| <input type="checkbox"/> Hydra Rig CT Test Well Facility | <input type="checkbox"/> SSR A60 Coiled Tubing Cabin |
| <input type="checkbox"/> PCE CT Tools CD | <input type="checkbox"/> Hydra Rig Nitrogen Equipment |
| <input type="checkbox"/> TOT CT Cutter | |

I'd like a sales representative to call me immediately.

My fax number is _____

Name _____

Title _____

Company _____

Phone _____

Address _____

City _____ State _____ Zip _____